

RPR-24PS

Elite Solid State

PULSE ISOLATION RELAY INSTRUCTION SHEET

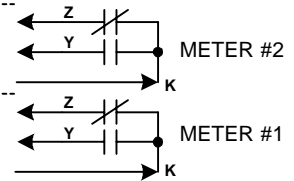
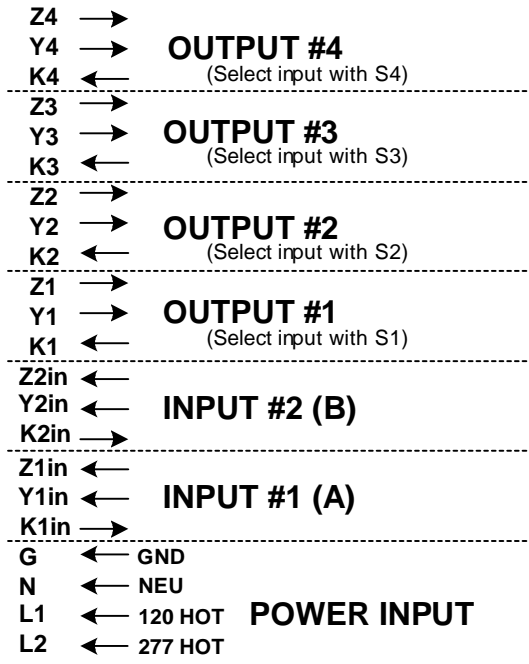
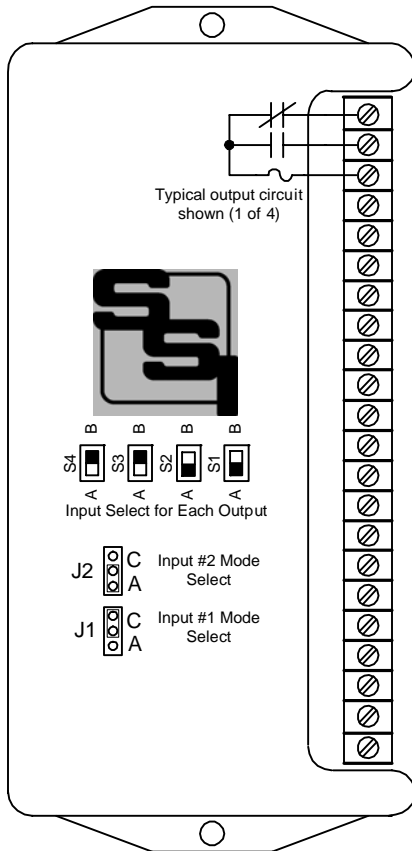

MOUNTING POSITION - The RPR-24PS may be mounted in any position.

POWER INPUT - For a power supply of 120VAC, connect the AC line's "hot" wire to the **L1** terminal. For 208 thru 277VAC, connect the AC line's "hot" wire to the **L2** terminal. The AC line's "neutral" wire should be connected to the **N** terminal. Connect the **G** terminal to the electrical system ground.

INPUT CONNECTIONS - Connect the K terminal of each meter which is supplying pulses to the RPR-24PS to the RPR-24PS' **K1in** and **K2in** terminals. Connect each meter's Y and Z terminals to the respective meter's **Yin** and **Zin** input terminals of the RPR-24PS.

INPUT TYPE SELECTION - The RPR-24PS' inputs may be configured as either 2-Wire (Form A) or 3-Wire (Form C). Selector Jumper J1 selects the configuration for INPUT #1. Selector Jumper J2 sets the configuration for INPUT #2. Place the Jumper Plug in the correct position for the input type desired: Bottom-to-middle pin for Form A (2-Wire), or middle-to-top pin for Form C (3-Wire).

FUSES - The fuses are type 3AG and may be up to 1/2 Amp in size. Four 1/2 Amp fuses (F1-F4) are supplied standard with the unit unless otherwise specified.

OUTPUTS - Four three-wire isolated outputs are provided on the RPR-24PS, with output terminals K1, Y1 & Z1; K2, Y2, & Z2; K3, Y3 & Z3; and K4, Y4 & Z4. Arc suppression for the contacts of the solid-state relays are provided internally. Each relay is assigned to one of the two input channels. Using the selector switch for each relay select "A" for Input #1 or "B" for Input #2. The output will follow the input selected.



SOLID STATE INSTRUMENTS

a division of Brayden Automation Corp.
 6230 Aviation Circle, Loveland Colorado 80538
 Phone: (970)461-9600 Fax: (970)461-9605
 E-mail: support@solidstateinstruments.com

RPR-24PS Wiring Diagram

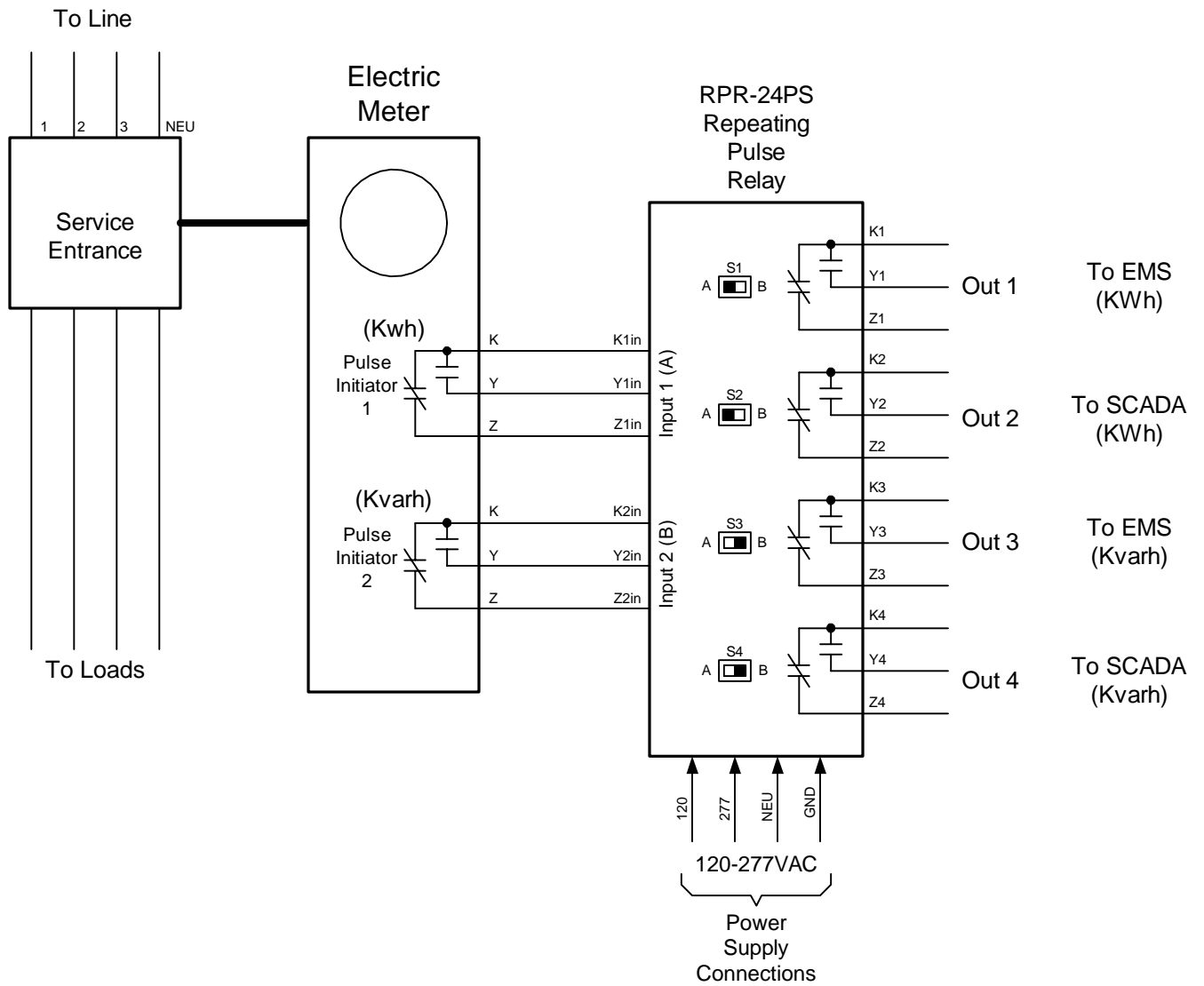

RPR-24PS Repeating Pulse Relay Wiring Diagram		REVISIONS	
		NO.	DATE
DATE ORIGINAL	SCALE		
5/5/11	N/A		
LATEST REVISION	JOB NO.	CHECKED	DRAWN
			WHB

**Brayden Automation Corp./
Solid State Instruments div.**
6230 Aviation Circle
Loveland, CO 80538
(970)461-9600
(970)461-9205 fax
www.solidstateinstruments.com